

R26 RTK User Manual

SMAJAYU(SHENZHEN)CO.LTD

Web:www.smajayu.com

Address:Room 213-214,Building 1,Mingliang Science Park,No.88,Zhuguang North Road,Taoyuan Street,Nanshan District,Shenzhen,China,518055.
Eml:support@smajayu.com&tech@smajayu.com.

Introduction

Welcome to use SMAJAYU RTK products, if you want to know more about intelligent RTK or other products of our company, welcome to visit our official website: www.smajayu.com.

This manual mainly introduces our RTK product (model: R26) and operation software and explains how to install, connect, set up and use the product. If there is any difference between the icons and pictures in the manual and the actual product, please refer to the actual product. In order to better use our RTK products, we recommend you to read this manual carefully before using the instrument.

Characteristics

> Efficient operation

- There is no complicated calibration process, such as rotation and leveling.
- Just hold the instrument to ensure that the bottom of the surveying rod does not move, and shake it back and forth in one direction for more than ten seconds to initialize the internal inertial guidance module and realize the tilt operation.
 - No need to check for bubbles in the 60° tilt range (recommended for use in the 30° tilt range to ensure accuracy).
 - At least 20% increase in measurement efficiency.
 - At least 20% increase in release efficiency.
 - Significantly reduces surveyor fatigue.

> Always high accuracy

- The receiver with integrated inertial guidance module ensures real-time interference-free tilt compensation, independent of any environmental influences such as geomagnetism and external metal structures.
 - 2.5CM tilt compensation accuracy.
 - Base station deviation warnings do not give the surveyor a chance to make a mistake.

Company Profile

SMAJAYU is a high-tech enterprise integrating R&D, production, sales and service. Based on BeiDou satellite navigation and expanding BeiDou industry applications, SMAJAYU is committed to providing customers with comprehensive and multi-area BeiDou high-precision navigation and positioning system solutions.

SMAJAYU follows the development trend of the world's four major satellite navigation systems, comprehensive layout of high-precision industry application promotion, to meet the differentiated application needs of different industries, product applications covering precision agriculture, intelligent transportation, machinery control, deformation monitoring, geographic information, surveying and mapping engineering and so on a variety of high-precision fields.

The company has more than 10 years of experience in product development, industry applications, product promotion and technical services in satellite navigation industry. Our main products and services cover high-precision GNSS boards, high-precision BeiDou/GNSS receivers, wireless data transmission equipments, combined navigation products, deformation monitoring systems, automatic driving systems, intelligent navigation, variable control and other products, solutions and related software development applications.

User instructions

- Before using this product, please read all the user information provided with the product carefully to understand the use of this product and the cautions.
- During outdoor installation of the base station equipment, the base station mainframe, etc., should pay attention to the long-term waterproof treatment, and the base station antenna must be placed in the outdoor open-air environment during use or testing.
- Do not detach or install the base station antenna or plug or unplug the connecting cables such as serial cables when the power is turned on.
- Please connect your device strictly according to the requirements in the manual. For cables such as DATA cable, you need to pinch the root of the plug and gently plug and unplug it, do not pull or rotate it, otherwise it will easily cause pin breakage.
- When supplying power to this product (system), you must pay attention to the equipment power supply requirements (the power supply voltage must be 9 to 36V).
- The base station transmitter radio may generate high temperature during use, please pay attention to avoid scalding, in addition, must avoid or reduce the radio surface unnecessary coverings, and maintain a good ventilation environment.
- When using the transmitting radio for a long time, people should keep a distance of more than 2 meters from the transmitting antenna to avoid radiation.
- When installing the antenna outdoors, users should pay attention to taking appropriate lightning protection measures to prevent lightning strikes.
- Please do not continue to use it after the breakage of each connecting cable, please purchase a replacement cable in time to avoid unnecessary harm affecting the use of the effect.
- equipment due to force majeure (lightning, high pressure, collision) damage, does not belong to our free maintenance coverage.
- Please do not detach the shell of this product by yourself, otherwise it will not be warranted.

Table of Contents

1、 PRODUCT INTRODUCTION	1
1.1 R26 Receiver Buttons and Lights	1
1.2 R26 Device Bottom Description	2
2、 RTK MEASUREMENT PROCESS	3
2.1 Device Setup	3
2.1.1 Base station setup	3
2.1.2 Rover Setup	6
2.2 Introduction to the Operation of the Flagship Edition of Surveying and Mapping	7
2.2.1 Create/open a new project	7
2.2.2 Connect the device	8

2.2.3	Setting the work mode of base station and rover	9
2.2.4	Parameter configuration	12
2.2.5	Surveying tasks	14
2.2.6	Results export	18
2.3	WEBUI Operation Introduction	19
2.3.1	Login and logout	19
2.3.2	Receiver Management	20
2.3.3	Receiver status	23
2.3.4	Receiver configuration	25
2.3.5	Data download	29
2.3.6	Language settings	29
3	FIRMWARE UPGRADE METHOD	30
4	ADVANCED FUNCTIONS	30
4.1	Base station deviation warning	30

1、 Product Introduction

1.1 R26 Receiver Buttons and Lights



Still recording button: Press and hold for 5 seconds to turn on or off the still recording mode.



Recorder light: red, flashes when the static recording mode is turned on, otherwise off.



Satellite light: red, RTK Fix is always on.



Differential light: red, flashes once per second when the radio or 4G module receives or sends data, and does not flash when there is no differential data.



Power light: three-color light, light blue when charging, green when fully charged, red when working, and red flashing when the battery is less than 10%.



Power button: Press and hold for 3 seconds to turn on the power, after turning on the power, press and hold for 3 seconds to voice announcement whether to turn off the power, short press after releasing the button to turn it off, press and hold for 3s to enter the self-test mode.

1.2 R26 Device Bottom Description



Anti-dust plugs: internal connectors are divided into base station and rover accessories



SMA26 configured with Type-C connector and SIM slot (SIM slot is reserved)



R26 V1 & V2 are 9 PIN aviation plugs, including power supply, COM RS232, CONFIG RS232, and no SIM card slot.



UHF radio antenna interface

2、RTK Measurement Process

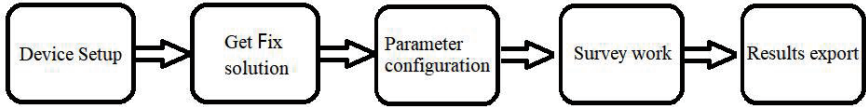

RTK Survey Process Diagram

2.1 Device Setup

2.1.1 Base station setup

Set up a tripod on a known or unknown point, and then install the base station receiver on the extended pole of the tripod or the base of the tripod; when setting up a known point, **it is necessary to purchase an additional foundation for centering and leveling.**

The diagram of the base station built-in radio with a whip radio antenna setup is shown as below:

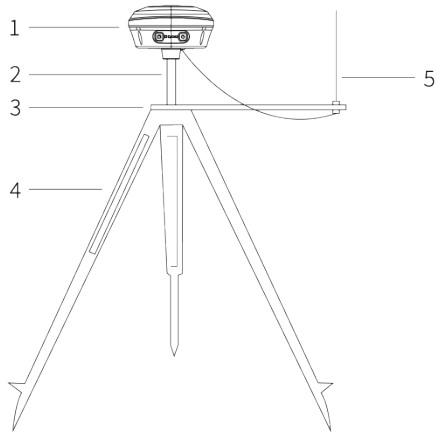

- 1 Base station 2 10CM extended pole 3 Extended board 4 Tripod
5 Whip radio antenna

The diagram of the base station built-in radio with a stick radio antenna setup is shown as below:

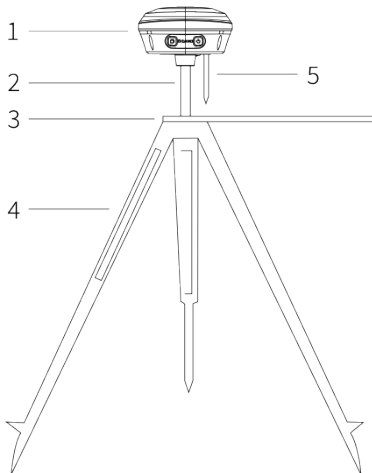

- 1 Base station 2 10CM extended pole 3 Extended board 4 Tripod
5 Stick radio antenna

NOTE: Both the Stick Radio Antenna and the Whip Radio Antenna are connected to the RADIO connector of the Base Station.

The diagram of the Base Station External Radio Antenna setup is shown as below:

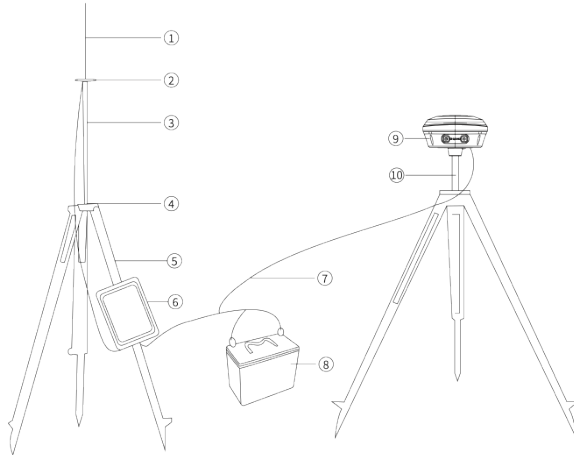

1、Whip antenna 2、Radio antenna connector 3、Radio antenna extended pole 4、
Aluminum plate 5、Tripod 6、Radio 7、Power cable + Digital Transmission Cable =
Radio Digital Integrated Cable 8、Battery 9、Base station 10、Extended pole

2.1.2 Rover Setup

The handheld bracket is installed on the surveying rod, the handbook is fixed to the handheld bracket, and the receiver is fixed to the surveying rod.

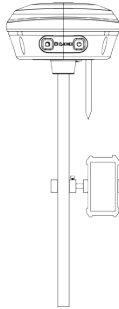

2.2 Introduction to the Operation of the Flagship Edition of Allypad

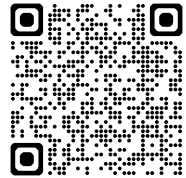

R26 instruction videos:

https://youtube.com/playlist?list=PLHbGTqOB2UpM6ai_kWdE0fxVyxQMjsiBC&si=zl5pB922JZSeaf8F



R26 related software and manuals:

<https://www.dropbox.com/sh/2xwlnanxgatdt0u/AAA0rxWEzxeWC9vPmaSkxytha?dl=0>

2.2.1 Create/open a new project

Click **【Project】** - **【Project Manager】** - **【New】**, fill in the information related to the project and the setting of coordinate system parameters in turn, select the coordinate system, modify the central meridian, and click OK, you can complete a new project.

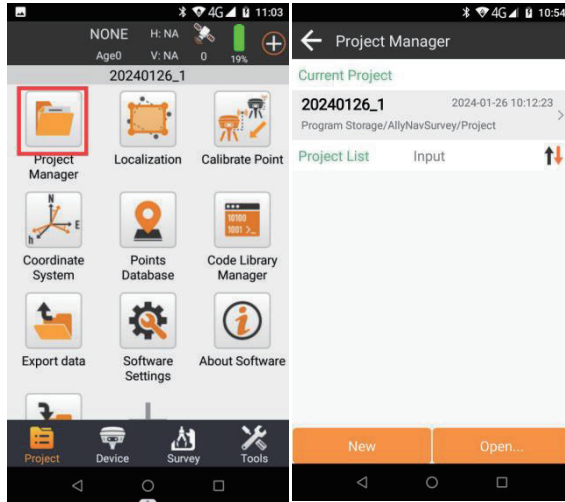

2.2.2 Connect the device

First of all, click **【Device】** - **【Communication】** to connect for the first time click on the blank area under the device parameters the software search for Bluetooth devices automatically, and then select the correct SN number of the RTK device and click on the connection.

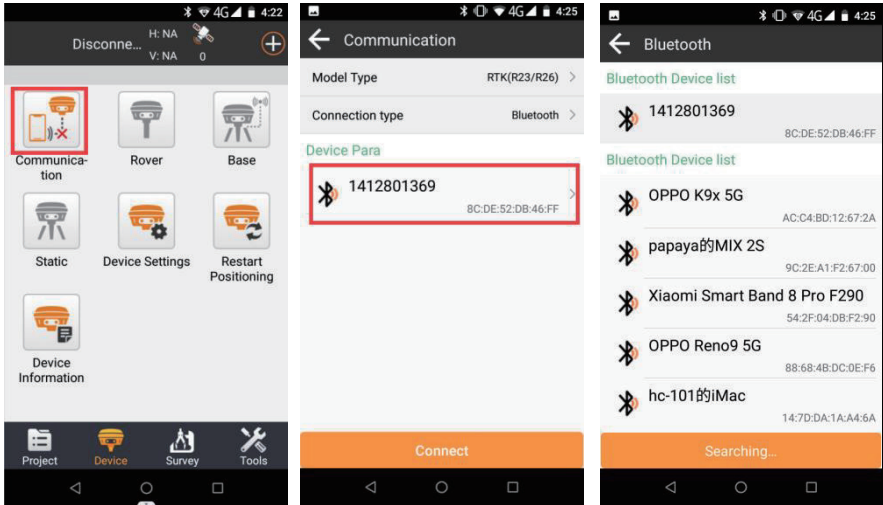

2.2.3 Setting the work mode of base station and rover

Tips for getting a fix solution:

1. Please ensure that all settings are performed outdoors in an open and unobstructed area, because obtaining a fix solution requires both base and rover to receive satellites. Please pay attention to the number of search stars at the top of the screen and try to ensure the number of search satellites is around 30.
2. After successfully setting up the base or rover, please wait 2 to 3 minutes for R26 to update the configuration information so that the fix solution can be obtained.
3. Please enter Communication first and connect to R26 through SN before starting the setup. Pay attention to distinguish base and rover through SN.

1. Base Station - built-in radio mode

【 Base Mode 】 - Select the Internal Radio - Select the corresponding channel frequency and other information.

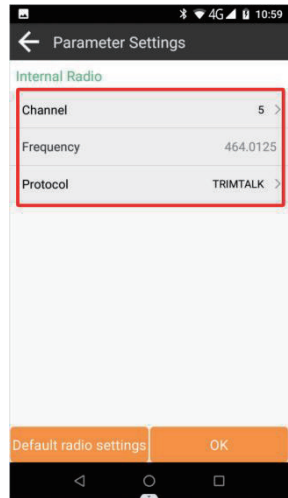
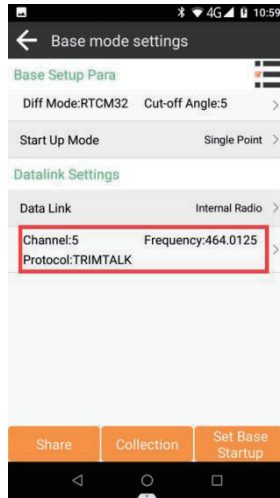
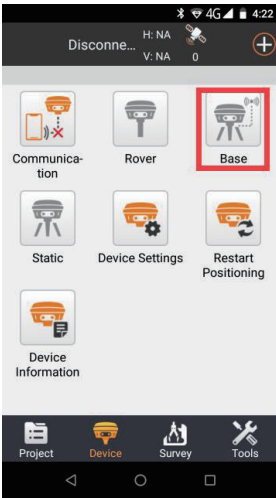

2. Rover - Radio Mode

1. First enter Communication --> Click stop to disconnect Bluetooth from base. Then connect to the Rover through SN. Please refer to Section 2.2.2 for the connection steps.

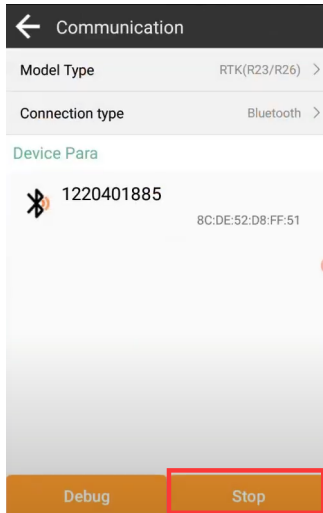

2. Enter the Rover mode - select the Internal Radio - select the corresponding channel frequency and other information.

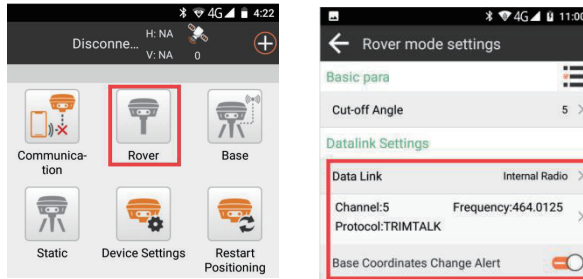

3. Rover-CORS Account Login

Enter the Rover mode - enter the Data Link - select Phone network , and fill in the corresponding IP address, port, user name and password. After getting the Mount Point, you can select the corresponding mount point.

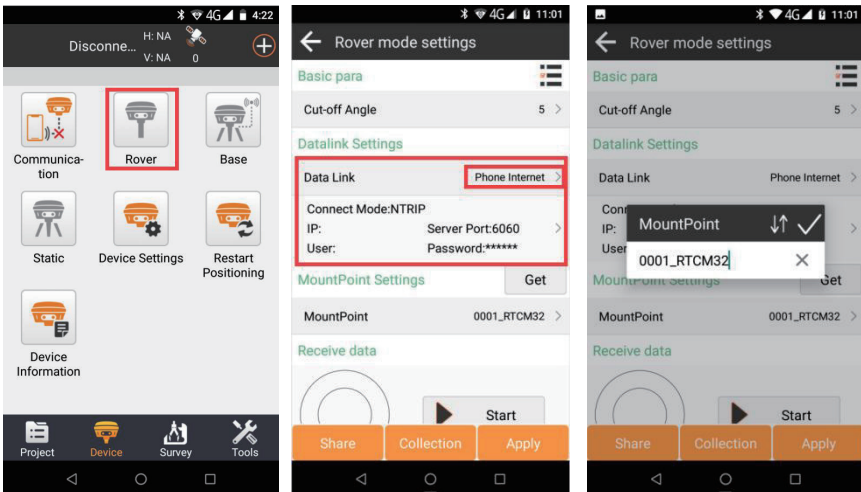

4. Rover - satellite station differential mode(PPP)

Enter rover mode - select satellite differential (B2b) or (E6) - then apply.

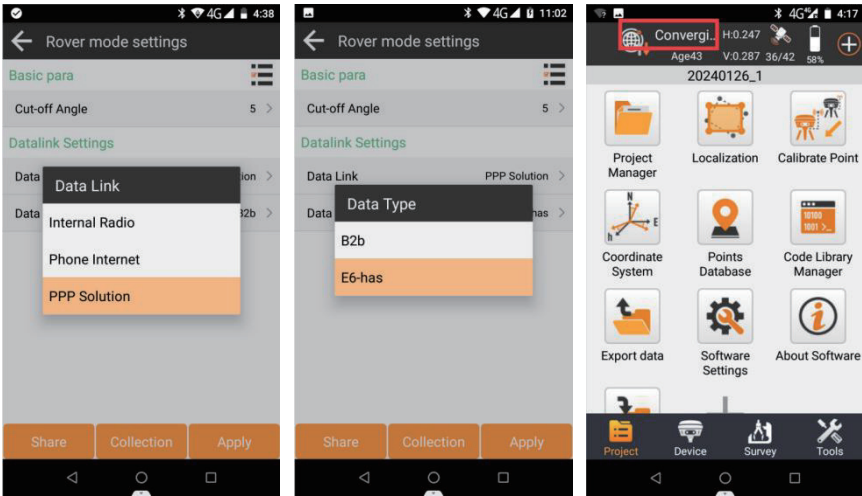

After application, place the receiver in an open area and wait for convergence, the PPP will be displayed when convergence is complete.

2.2.4 Parameter configuration

1. Localization

Input the known coordinates of control points in the coordinate point library, and collect the original WGS-84 coordinates on the corresponding control points.

Enter the Localization menu, click Add, select the input control point for the Known Point Coordinates, select the collected point for the GNSS Point Coordinates, and click Calculate to get the result of the conversion parameter calculation after selection.

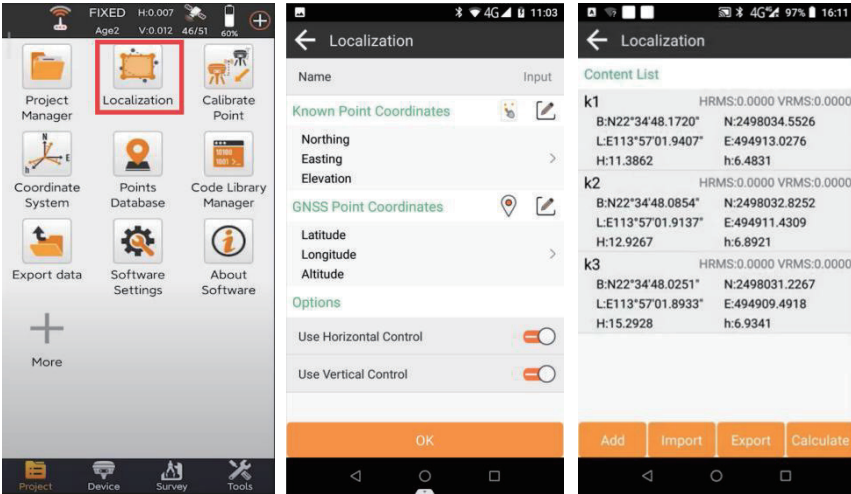

2. Calibrate Point

Base station moving or shutdown and restart, need to do base station leveling. Enter the Calibrate Point, GNSS Point Coordinates are the coordinates of the receiver that will be collected, Known Point Coordinates to select the corresponding known coordinates of the point and click OK after selecting the point.

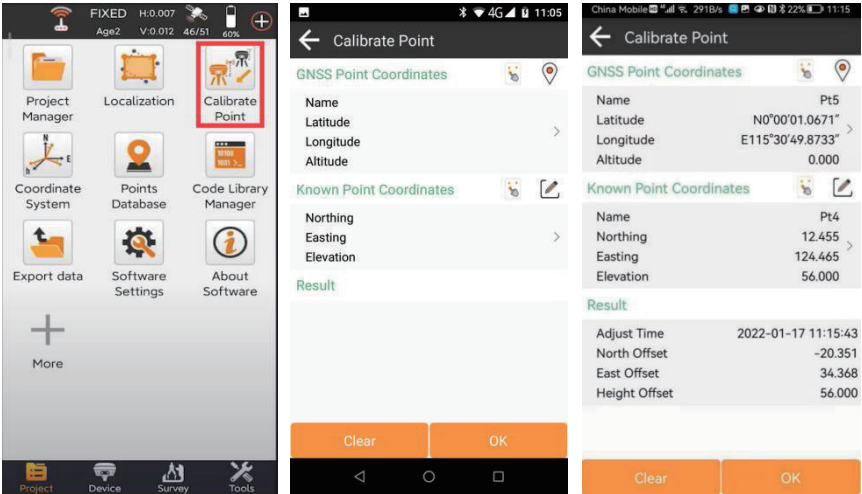

2.2.5 Surveying tasks

1. Point survey

Select [Survey] - [Point Survey] menu to enter the point survey interface, enter the point name, pole height and other information, and then click the  button to collect the point after correcting the surveying rod, and the collected point can be checked in the Point Database.

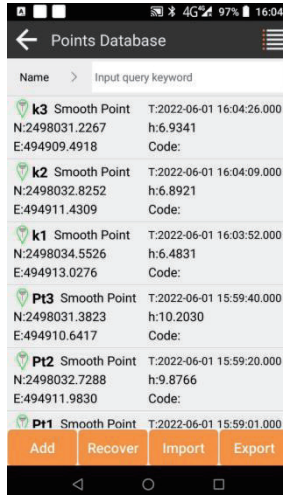

2.Tilt Survey

Open the Tilt Survey button in the Point Survey interface and follow the prompts to calibrate and set the antenna height, the antenna height can be changed at any time, after the setting is completed, it shows that the inertial guidance is available and point survey can be performed.

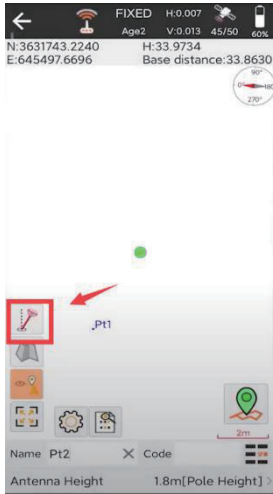

3.Point stakeout

Click [Survey] - [Point Stakeout] to add a point or select a point from the library to import the stakeout point into the point to be stakeout.

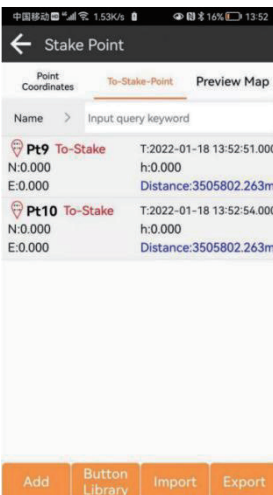
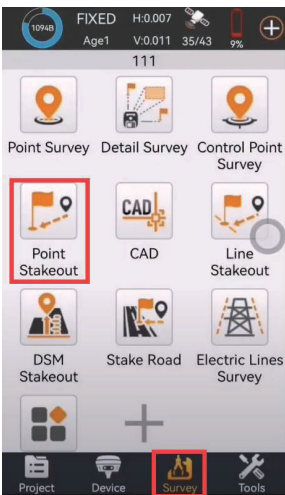

4. Coordinate Calculation

Click [Tools] - [Coordinate positive calculation] to calculate the coordinates of the target point by adding the coordinates of two known points and the azimuth and distance of the target point; in addition, the north direction only requires one known point and azimuth and coordinates, click the North direction switch.

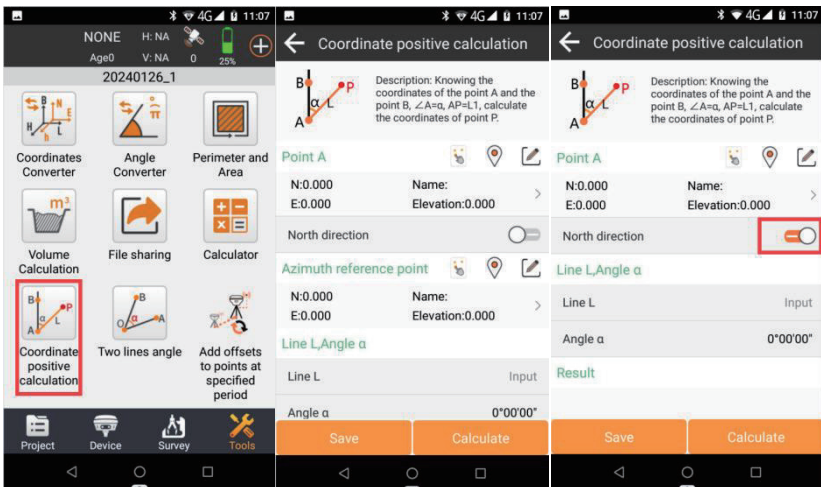

5. Coordinate back-calculation

Click [Tools] - [Coordinate inverse calculation] to find the azimuth of two points AB and the plane distance ,space distance, elevation difference and slope ratio of AB by adding the coordinates of two known points.

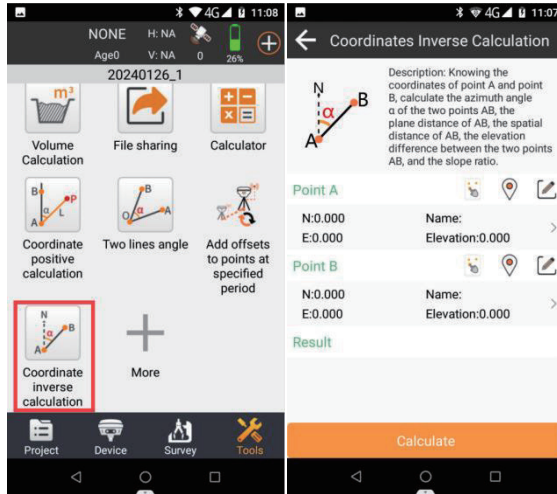

2.2.6 Results export

As shown in the figure, select (multiple choices) the data format you need to export, select the export location and enter the export file name, click Export to complete the data export. If you choose to export multiple formats, it will be generated into a folder.

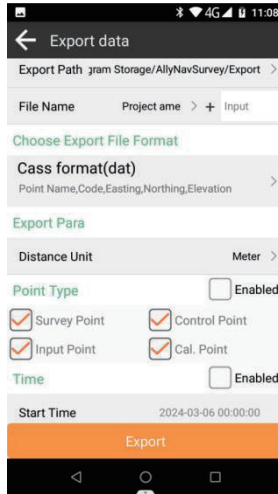

2.3 WEBUI Operation Introduction

Note: Only SMA26 supports this operation

2.3.1 Login and logout

Use the terminal device to connect to the receiver WiFi, enter the default password: 12345678, and enter the browser IP address in the browser of the terminal device (IP address: 192.168.1.1), the GNSS receiver web configuration system login interface. As shown in the following figure: user name: admin, password: password.



2.3.2 Receiver Management

Receiver Information

In the device management interface, the online receiver will display a green **Receiver Management** button, after clicking the button, the browser opens the receiver's management interface in a new tab page. It displays the information of all hardware parameters of the connected receiver. The interface is shown in the picture below:

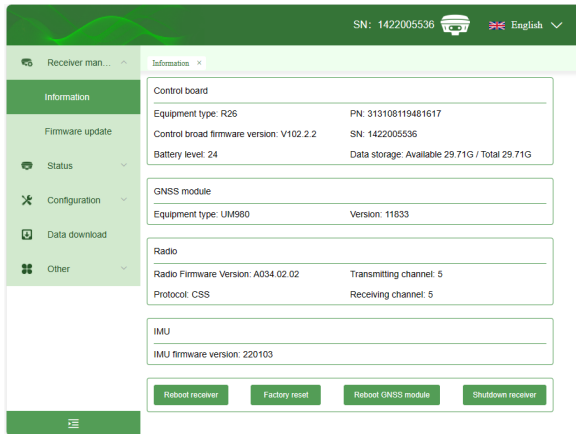

- 1) After entering, the default "Information" page will be displayed, showing the host and module information of the connected receiver.
- 2) The receiver information is:
 - Type of device, SN, PN, the firmware version of baseboard, data storage, battery level, the firmware version of mainboard, the firmware version of setup radio, and the firmware version of IMU.
 - Operation: 4 operations can be performed on the receiver.

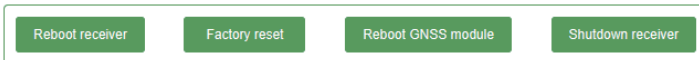

Reboot receiver: After clicking "Reboot", a prompt pops up, "whether to reboot the receiver?", click "OK". After clicking "OK", the receiver will be rebooted, and it will prompt "Reboot Successful" when reboot is successful. If

reboot is failed, "Reboot Failed" will be prompted. Click "Cancel", then the prompt disappears without doing any operation.

Factory reset: Factory reset clears the configuration parameters of the receiver.

Reboot GNSS module: Reboot GNSS module is to reset the positioning board of the receiver and search the satellite again to get the positioning data.

Shutdown receiver: Turn off the receiver.

Firmware upgrade

Firmware upgrade is performed for the receiver host and each module. It can be performed to upgrade the firmware of the main unit, GNSS, radio, and IMU.

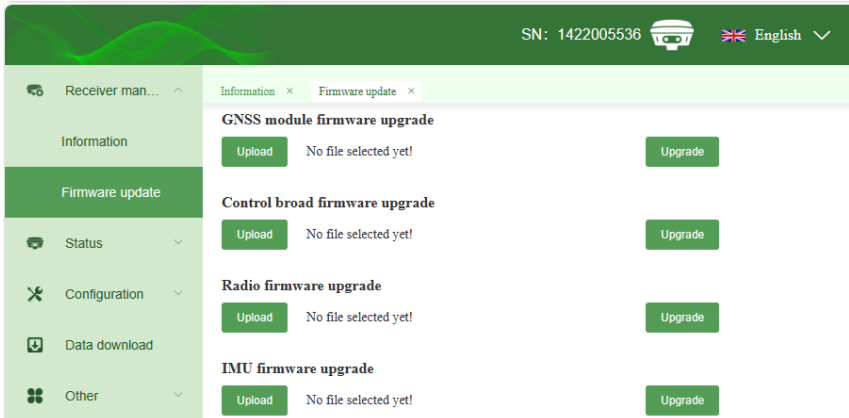

Select file: Click "Click Upload" to enter the pop-up window for selecting local files,

there is no limitation on the file types.

Tip: The file size should not exceed 2M, if it exceeds 2M, the uploaded file is too large, please re-upload. After the file is selected, the file name will be displayed on the page.

Firmware upgrade: Click the Firmware Upgrade button, the page will show loading when upgrading, and a pop-up window will appear to indicate that the upgrade is successful, or a pop-up window will appear to indicate that the upgrade has failed.

2.3.3 Receiver status

location information

Click the menu line **Position** to enter the interface, which displays the receiver latitude and longitude, geodetic height, number of tracking satellites, UTC time and other related information. The interface is shown in the picture below:

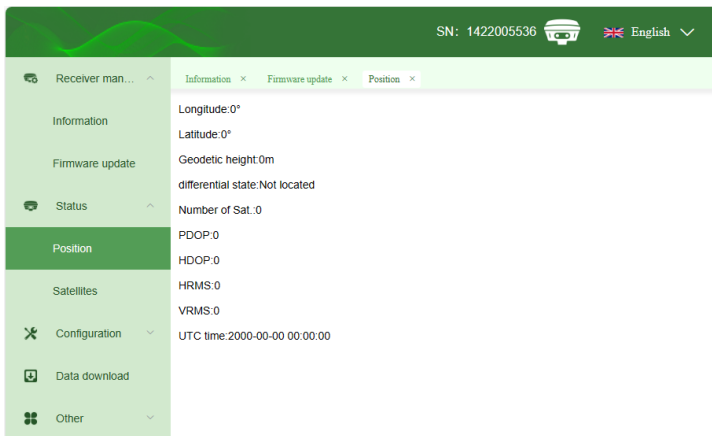

Satellites

Click the menu line **Satellites** to enter the interface, which displays the list of satellites tracked by the receiver, the satellite star map, and the satellite signal-to-noise ratio information. The satellite list is shown in the picture below:

Sat. type	SV	Altitude	Azimuth	L1/B1	L2/B2	L5/B3
BDS	40	67	332	29	0	0
GPS	7	28	323	32	0	0
GPS	27	42	31	26	0	0
GPS	26	8	80	27	0	0
GLONASS	75	17	323	26	0	0
GLONASS	74	42	21	36	0	0
GALILEO	27	38	315	32	0	0

signal-to-noise ratio

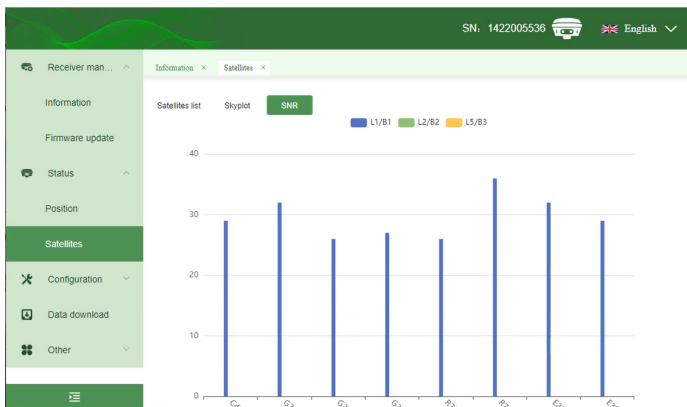

2.3.4 Receiver configuration

Working mode

Sets the working mode of the receiver. Currently, the base station and rover settings are supported.

Set the receiver in base station mode. Set the receiver position (currently supports manual input or location acquisition); data link configuration is to configure the corrected data format, transmission data chain, transmission protocol (supports TCP and Ntrip protocols) and other information; click the **Save** button after the configuration is completed.

Base station fixed coordinate radio mode.

The screenshot displays the configuration interface for the SMAJAYU R26 RTK receiver. The top status bar shows the serial number (SN: 1422005536) and the language set to English. The left sidebar contains navigation options: Information, Firmware update, Status, Position, Satellites, Configuration, Antenna settings, Working mode (highlighted), Sat. settings, Data download, and Other. The main content area is titled 'Working mode selection' and includes the following settings:

- Working mode selection:** Working mode: Base station
- Location settings:**
 - Boot mode: Fixed coordinates
 - Lat. and Lon. format: ±DDD°MM'SS.SSSSS"
 - Longitude: Longit (three input fields)
 - Latitude: Latitu (three input fields)
 - Elevation: Elevation m (input field) and a 'Get the current coordinates' button.
- Data link configuration:**
 - Differential type: RTCM3.2
 - Data link: Internal radio
 - Radio channel: 5

Rover radio mode

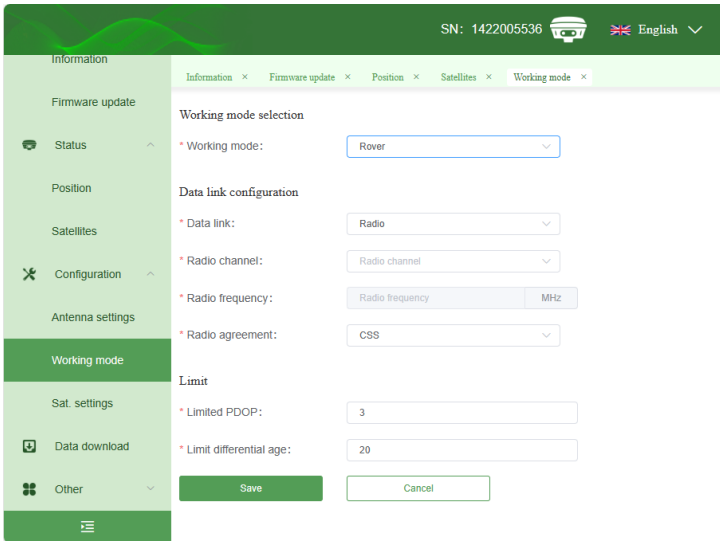

Rover network linking model

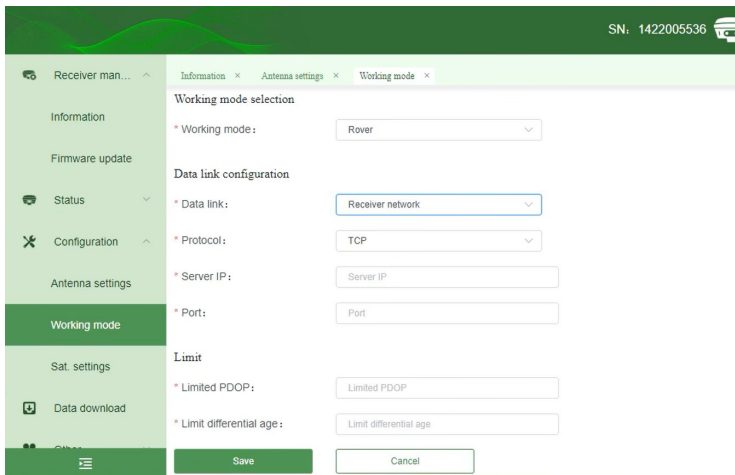

Static station working mode

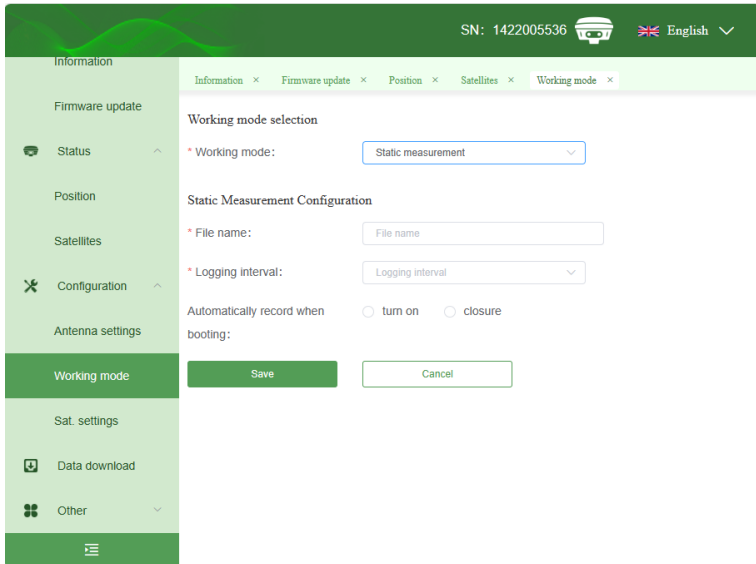

Antenna setting

Click the menu line **Antenna Setting** to enter the interface, in which you can configure the antenna measurement method, input the antenna measurement height, and the platform will automatically calculate the height of the antenna phase center, and click **Save** button to save the settings.

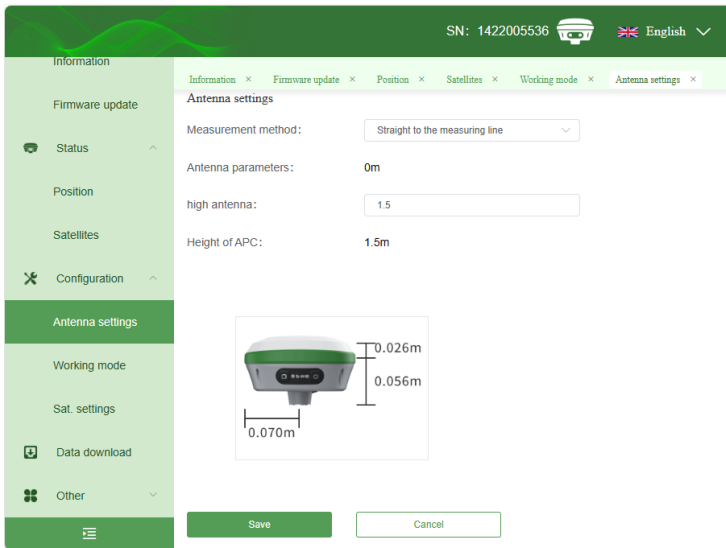

Satellite settings

Click the menu line **Satellite Settings** to enter the interface, in which you can configure the satellite constellation to enable/disable, set the satellite altitude cutoff angle, and click the **Save** button to save the settings.

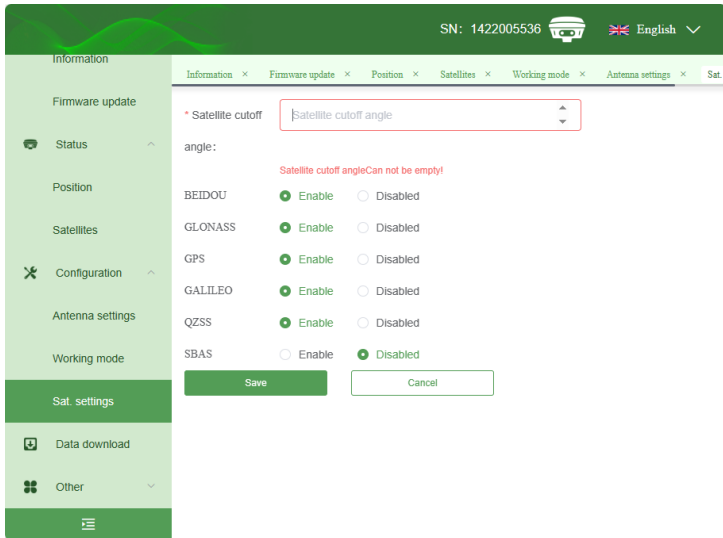

2.3.5 Data download

Download static data from the receiver.

2.3.6 Language settings

Language selection

In the WEBUI interface, click the **National Flag** button. Select the corresponding country to change the interface language, and the receiver will change the voice at the same time. Currently, it supports 5 languages (Chinese, English, Russian, Turkish, Spanish).

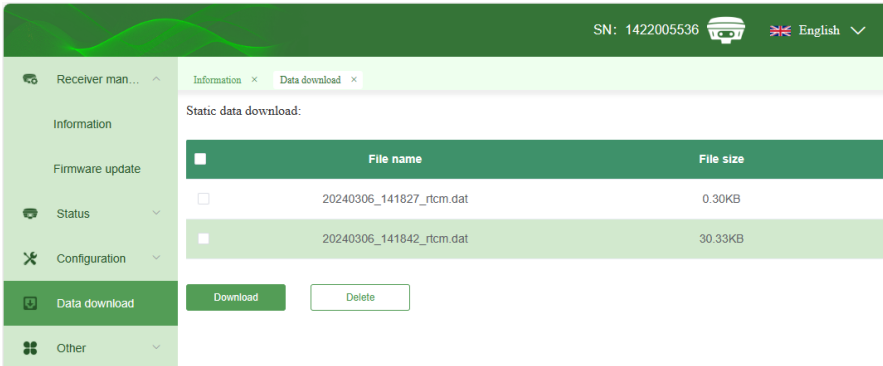

3、Firmware Upgrade Method

The main unit can be upgraded on the WEBUI or through the data cable if it needs the firmware to be upgraded.

4、Advanced Functions

Advanced functions include base station deviation warning, which is recommended to be operated after you have already skillfully operated the regular functions or under the guidance of professional operators.

4.1 Base station deviation warning

When the base station is tilted or shifted by a collision, the mapping system sends out an alert on the change of the base station coordinates. At this time, the collected coordinates are no longer accurate, and the base station must be shut down and restarted to reset the base station offset before operation.

About Us

SMAJAYU was built in 2009, 10years+ experienced the technology changes from traditional devices to smart equipments. Intelligent agriculture empowered SMAJAYU new mission to support Agriculture development.

High-precision and affordable RTK GNSS system boosts the farming technology adoption across all-size farms. Integrated with GPS accuracy technology, SMAJAYU agriculture guidance and auto-steer ensure centimeters precision farming.

The main goals of SMAJAYU intelligent agriculture is optimizing farmer's work, reducing input costs and increasing farm income, promoting farm environment, increasing farm production.

✉ Eml: support@smajayu.com & tech@smajayu.com

☎ +86-13823325452

